

Low Voltage Motors

Manual for Low Voltage Motors



- Installation, operation, maintenance and safety manual EN 3
- Montage-, Betriebs-, Wartungs- und Sicherheitsanleitung DE 21
- Manuel d'installation, d'exploitation, de maintenance et de sécurité FR 39
- Manual de instalación, funcionamiento, mantenimiento y seguridad ES 57
- Manuale d'installazione, funzionamento e manutenzione..... IT 75
- Installations-, drifts-, underhålls- och säkerhetsmanual SV 93
- Asennus-, käyttö-, kunnossapito- ja turvallisuusohje FI 111

More languages – see web site
www.abb.com/motors&generators >
Motors > Document library

ABB



EC Declaration of Conformity

The Manufacturer: *(Name and address of the manufacturer)*

hereby declares that

The Products: *(Product identification)*

are in conformity with the corresponding essential requirements of following EC directive:

Directive 2006/95/EC (of 12 December 2006).

The motors are in compliance with the following harmonized standard:

EN 60 034-1(2004)

which thus comply with Principal Elements of the Safety Objectives for Electrical Equipement stated in Annex I of said directive.

Note: When installing motors for converter supply applications, additional requirements must be respected regarding the motor as well as the installation, as described in installation manual delivered with converters.

Year of CE marking :

Signed by -----

Title -----

Date -----

Low Voltage Motors

Installation, operation, maintenance and safety manual

List of Contents	Page
1. Introduction	5
1.1 Declaration of Conformity	5
1.2 Validity	5
2. Handling	6
2.1 Reception check	6
2.2 Transportation and storage	6
2.3 Lifting	6
2.4 Machine weight	6
3. Installation and commissioning	7
3.1 General	7
3.2 Insulation resistance check	7
3.3 Foundation	7
3.4 Balancing and fitting coupling halves and pulleys	8
3.5 Mounting and alignment of the motor	8
3.6 Slide rails and belt drives	8
3.7 Machines with drain plugs for condensation	8
3.8 Cabling and electrical connections	8
3.8.1 Connections for different starting methods	9
3.8.2 Connections of auxiliaries	9
3.9 Terminals and direction of rotation	9
4. Operation	10
4.1 Use	10
4.2 Cooling	10
4.3 Safety considerations	10
5. Low voltage motors in variable speed operation	11
5.1 Introduction	11
5.2 Winding insulation	11
5.2.1 Phase to phase voltages	11
5.2.1 Phase to ground voltages	11
5.2.3 Selection of winding insulation for ACS550- and ACS800-converters	11
5.2.4 Selection of winding insulation with all other converters	11

5.3	Thermal protection of windings	11
5.4	Bearing currents	11
5.4.1	Elimination of bearing currents with ABB ACS550 and ACS800 converters	12
5.4.2	Elimination of bearing currents with all other converters	12
5.5	Cabling, grounding and EMC	12
5.6	Operating speed	12
5.7	Dimensioning the motor for variable speed application	12
5.7.1	General	12
5.7.2	Dimensioning with ABB ACS800 converters with DTC control	12
5.7.3	Dimensioning with ABB ACS550 converters	13
5.7.4	Dimensioning with other voltage source PWM-type converters	13
5.7.5	Short time overloads	13
5.8	Rating plates	13
5.9	Commissioning the variable speed application	13
6.	Maintenance	14
6.1.	General inspection	14
6.2	Lubrication	14
6.2.1	Machines with permanently greased bearings	14
6.2.2	Motors with regreasable bearings	15
6.2.3	Lubrication intervals and amounts	15
6.2.4	Lubricants	17
7.	After Sales Support	18
7.1.	Spare parts	18
7.2	Rewinding	18
7.3	Bearings	18
8.	Environmental requirements	18
8.1	Noise levels	18
9.	Troubleshooting	19

1. Introduction

NOTE!

These instructions must be followed to ensure safe and proper installation, operation and maintenance of the machine. They should be brought to the attention of anyone who installs, operates or maintains the machine or associated equipment. The machine is intended for installation and use by qualified personnel, familiar with health and safety requirements and national legislation. Ignoring these instructions may invalidate all applicable warranties.

1.1 Declaration of Conformity

Declarations of Conformity with respect to the Low voltage Directive 73/23/EEC amended by Directive 93/68 EEC are issued separately with individual machines.

The Declaration of Conformity also satisfies the requirements of a Declaration of Incorporation with respect to the Machinery Directive 98/37/EEC, Art 4.2 Annex II, sub B

1.2 Validity

The instructions are valid for the following ABB electrical machine types, in both motor and generator operation.

series MT*, MXMA,
series M2A*/M3A*, M2B*/M3B*, M4B*, M2C*/M3C*,
M2F*/M3F*, M2L*/M3L*, M2M*/M3M*, M2Q*,
M2R*/M3R*, M2V*/M3V*
in frame sizes 56 - 450.

There is a separate manual for e.g. Ex motors 'Low voltage motors for hazardous areas: Installation, operation and maintenance Manual' (Low Voltage Motors/ Manual for Ex-motors).

Additional information is required for some machine types due to special application and/or design considerations.

Additional information is available for the following motors:

- roller table motors
- water cooled motors
- open drip proof motors
- smoke venting motors
- brake motors
- motors for high ambient temperatures

2. Handling

NE

2.1 Reception check

Immediately upon receipt check the motor for external damage (e.g. shaft-ends and flanges and painted surfaces) and if found, inform the forwarding agent without delay.

Check all rating plate data, especially voltage and winding connection (star or delta). The type of bearing is specified on the rating plate of all motors except the smallest frame sizes.

2.2 Transportation and storage

The motor should always be stored indoors (above -20°C), in dry, vibration free and dust free conditions. During transportation, shocks, falls and humidity should be avoided. In other conditions, please contact ABB.

Unprotected machined surfaces (shaft-ends and flanges) should be treated against corrosion.

It is recommended that shafts are rotated periodically by hand to prevent grease migration.

Anti-condensation heaters, if fitted, are recommended to be used to avoid water condensing in the motor.

The motor must not be subject to any external vibrations at standstill so as to avoid causing damage to the bearings.

Motors fitted with cylindrical-roller and/or angular contact bearings must be fitted with locking devices during transport.

2.3 Lifting

All ABB motors above 25 kg are equipped with lifting lugs or eyebolts.

Only the main lifting lugs or eyebolts of the motor should be used for lifting the motor. They must not be used to lift the motor when it is attached to other equipment.

Lifting lugs for auxiliaries (e.g. brakes, separate cooling fans) or terminal boxes must not be used for lifting the motor.

Motors with the same frame may have a different

center of gravity because of different output, mounting arrangements and auxiliary equipment.

Damaged lifting lugs must not be used. Check that eyebolts or integrated lifting lugs are undamaged before lifting.

Lifting eyebolts must be tightened before lifting. If needed, the position of the eyebolt can be adjusted using suitable washers as spacers.

Ensure that proper lifting equipment is used and that the sizes of the hooks are suitable for the lifting lugs.

Care must be taken not to damage auxiliary equipment and cables connected to the motor.

2.4 Machine weight

The total machine weight can vary within the same frame size (center height) depending on different output, mounting arrangement and auxiliaries.

The following table shows estimated maximum weights for machines in their basic versions as a function of frame material.

The actual weight of all ABB's motors, except the smallest frame sizes (56 and 63) is shown on the rating plate.

Frame size	Aluminum Weight kg	Cast iron Weight kg	Steel Weight kg	Add. for brake
56	4.5	-		-
63	6	-		-
71	8	13		5
80	12	20		8
90	17	30		10
100	25	40		16
112	36	50		20
132	63	90		30
160	95	130		30
180	135	190		45
200	200	275		55
225	265	360		75
250	305	405		75
280	390	800	600	-
315	-	1700	1000	-
355	-	2700	2200	-
400	-	3500	3000	-
450	-	4500	-	-

3. Installation and commissioning

WARNING

Disconnect and lock out before working on the motor or the driven equipment.

3.1 General

All rating plate values must be carefully checked to ensure that the motor protection and connection will be properly done.

WARNING

In case of motors mounted with the shaft upwards and water or liquids are expected to go down along the shaft, the user must take in account to mount some means capable of preventing it.

Remove transport locking if employed. Turn shaft by hand to check free rotation if possible.

Motors equipped with roller bearings:

Running the motor with no radial force applied to the shaft may damage the roller bearing.

Motors equipped with angular contact bearing:

Running the motor with no axial force applied in the right direction in relation to the shaft may damage the angular contact bearing.

WARNING

For machines with angular contact bearings the axial force must not by any means change direction.

The type of bearing is specified on the rating plate.

Motors equipped with regreasing nipples:

When starting the motor for the first time, or after long storage, apply the specified quantity of grease.

For details, see section "6.2.2 Motors with regreasable bearings".

3.2 Insulation resistance check

Measure insulation resistance before commissioning and when winding dampness is suspected.

WARNING

Disconnect and lock out before working on the motor or the driven equipment.

Insulation resistance, corrected to 25°C, must exceed the reference value, i.e. 100 MΩ (measured with 500 or 1000 V DC). The insulation resistance value is halved for each 20°C rise in ambient temperature.

WARNING

The motor frame must be grounded and the windings should be discharged against the frame immediately after each measurement to avoid risk of electrical shock.

If the reference resistance value is not attained, the winding is too damp and must be oven dried. The oven temperature should be 90°C for 12-16 hours followed by 105°C for 6-8 hours.

Drain hole plugs, if fitted, must be removed and closing valves, if fitted, must be opened during heating. After heating, make sure the plugs are refitted. Even if the drain plugs are fitted, it is recommended to disassemble the end shields and terminal box covers for the drying process.

Windings drenched in seawater normally need to be rewound.

3.3 Foundation

The end user has full responsibility for preparation of the foundation.

Metal foundations should be painted to avoid corrosion.

Foundations must be even, see figure below, and sufficiently rigid to withstand possible short circuit forces. They must be designed and dimensioned to avoid the transfer of vibration to the motor and vibration caused by resonance.

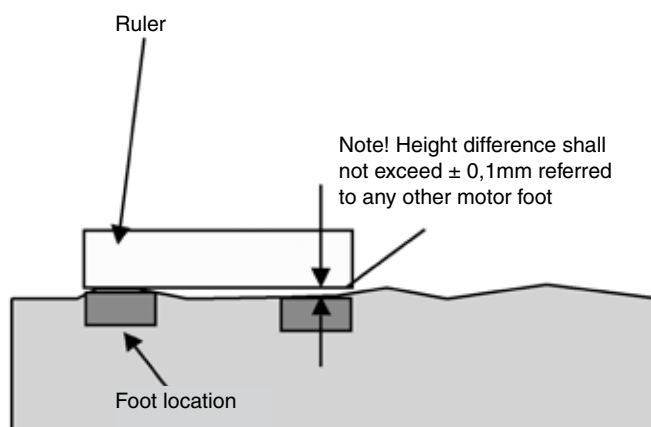

3.4 Balancing and fitting coupling halves and pulleys

As standard, balancing of the motor has been carried out using half key

When balancing with full key, the shaft is marked with YELLOW tape, with the text "Balanced with full key".

In case of balancing without key, the shaft is marked with BLUE tape, with the text "Balanced without key".

Coupling halves or pulleys must be balanced after machining the keyways. Balancing must be done in accordance with the balancing method specified for the motor.

Coupling halves and pulleys must be fitted on the shaft by using suitable equipment and tools which do not damage the bearings and seals.

Never fit a coupling half or pulley by hammering or by removing it using a lever pressed against the body of the motor.

3.5 Mounting and alignment of the motor

Ensure that there is enough space for free airflow around the motor. Minimum requirements for free space behind the motor fan cover can be found from the product catalog or from the dimension drawings available from the web: see www.abb.com/motors&generators.

Correct alignment is essential to avoid bearing, vibration and possible shaft failures.

Mount the motor on the foundation using the appropriate bolts or studs and place shim plates between the foundation and the feet.

Align the motor using appropriate methods.

If applicable, drill locating holes and fix the locating pins into position.

Mounting accuracy of coupling half: check that clearance b is less than 0.05 mm and that the difference a_1 to a_2 is also less than 0.05 mm. See Figure 3.

Re-check the alignment after final tightening of the bolts or studs.

Do not exceed permissible loading values for bearings as stated in the product catalogues.

3.6 Slide rails and belt drives

Fasten the motor to the slide rails as shown in Figure 2.

Place the slide rails horizontally on the same level.

Check that the motor shaft is parallel with the drive shaft.

Belts must be tensioned according to the instructions of the supplier of the driven equipment. However, do not exceed the maximum belt forces (i.e. radial bearing loading) stated in the relevant product catalogues.

WARNING

Excessive belt tension will damage bearings and can cause shaft damage.

3.7 Machines with drain plugs for condensation

Check that drain holes and plugs face downwards.

Machines with sealable plastic drain plugs are delivered in open position. In very dusty environments, all drain holes should be closed.

3.8 Cabling and electrical connections

The terminal box on standard single speed motors normally contains six winding terminals and at least one earth terminal.

In addition to the main winding and earthing terminals, the terminal box can also contain connections for thermistors, heating elements or other auxiliary devices.

Suitable cable lugs must be used for the connection of all main cables. Cables for auxiliaries can be connected into their terminal blocks as such.

Machines are intended for fixed installation only. If not otherwise specified, cable entry threads are metric. The IP-class of the cable gland must be at least the same as those of the terminal boxes.

Unused cable entries must be closed with blanking elements according to the IP class of the terminal box.

The degree of protection and diameter are specified in the documents relating to the cable gland.

WARNING

Use appropriate cable glands and seals in the cable entries according to the type and diameter of the cable.

Additional information on cables and glands suitable for variable speed applications can be found from chapter 5.5.

Earthing must be carried out according to local regulations before the machine is connected to the supply voltage.

Ensure that the motor protection corresponds to the environment and weather conditions; for example, make sure that water cannot enter the motor or the terminal boxes.

The seals of terminal boxes must be placed correctly in the slots provided, to ensure the correct IP class.

3.8.1 Connections for different starting methods

The terminal box on standard single speed motors normally contains six winding terminals and at least one earth terminal. This enables the use of DOL- or Y/D-starting. See Figure 1.

For two-speed and special motors, the supply connection must follow the instructions inside the terminal box or in the motor manual.

The voltage and connection are stamped on the rating plate.

Direct-on-line starting (DOL):

Y or D winding connections may be used.

For example, 690 VY, 400 VD indicates Y-connection for 690 V and D-connection for 400 V.

Star/Delta starting (Y/D):

The supply voltage must be equal to the rated voltage of the motor when using a D-connection.

Remove all connection links from the terminal block.

Other starting methods and severe starting conditions:

In case other starting methods are used, such as a soft starter, or if starting conditions are particularly difficult, please consult ABB first.

3.8.2 Connections of auxiliaries

If a motor is equipped with thermistors or other RTDs (Pt100, thermal relays, etc.) and auxiliary devices, it is recommended they be used and connected by appropriate means. Connection diagrams for auxiliary elements and connection parts can be found inside the terminal box.

Maximum measuring voltage for the thermistors is 2.5 V. Maximum measuring current for Pt100 is 5 mA. Using a higher measuring voltage or current may cause errors in readings or damage the system.

The insulations of the winding thermal sensors is of basic type. While connecting the sensors to control systems etc, ensure adequate insulation or isolation, see IEC 60664.

NOTE!

Ensure the insulation level or isolation of thermistor circuit, see IEC 60664.

3.9 Terminals and direction of rotation

The shaft rotates clockwise when viewing the shaft face at the motor drive end, and the line phase sequence - L1, L2, L3 - is connected to the terminals as shown in Figure 1.

To alter the direction of rotation, interchange any two connections on the supply cables.

If the motor has a unidirectional fan, ensure that it rotates in the same direction as the arrow marked on the motor.

4. Operation



4.1 Use

The motors are designed for the following conditions unless otherwise stated on the rating plate.

- Normal ambient temperature limits are -20°C to +40°C.
- Maximum altitude 1000 m above sea level.
- Tolerance for supply voltage is $\pm 5\%$ and for frequency $\pm 2\%$ according to EN / IEC 60034-1 (2004).

The motor can only be used in applications it is intended for. The rated nominal values and operational conditions are shown on the motor rating plates. In addition, all requirements of this manual and other related instructions and standards must be followed.

If these limits are exceeded, motor data and construction data must be checked. Please contact ABB for further information.

WARNING

Ignoring any of given instructions or maintenance of the apparatus may jeopardize the safety and thus prevents the use of the machine.

4.2. Cooling

Check that the motor has sufficient airflow. Ensure that no nearby objects or direct sunshine radiate additional heat to the motor.

For flange mounted motors (e.g. B5, B35, V1), make sure that the construction allows sufficient air flow on the outer surface of the flange.

4.3. Safety considerations

The machine is intended for installation and use by qualified personnel, familiar with health and safety requirements and national legislation.

Safety equipment necessary for the prevention of accidents at the installation and operating site must be provided in accordance with local regulations.

WARNING

Do not carry out work on motor, connection cables or accessories such as frequency converters, starters, brakes, thermistor cables or heating elements when voltage is applied.

Points to observe

1. Do not step on the motor.
2. The temperature of the outer casing of the motor may be too hot to touch during normal operation and especially after shut-down.
3. Some special motor applications require special instructions (e.g. using frequency converter supplies).
4. Be aware of rotating parts of the motor.
5. Do not open terminal boxes while energized.

5. Low voltage motors in variable speed operation

5.1 Introduction

This part of the manual provides additional instructions for motors used in frequency converter supply. Instructions provided in this and respective manuals of selected frequency converter must be followed to ensure safety and availability of the motor.

Additional information may be required by ABB to decide on the suitability for some machine types used in special applications or with special design modifications.

5.2 Winding insulation

Variable speed drives cause higher voltage stresses than the sinusoidal supply on the winding of the motor and therefore the winding insulation of the motor as well as the filter at the converter output must be dimensioned according following instructions.

5.2.1 Phase to phase voltages

The maximum allowed phase to phase voltage peaks at the motor terminal as a function of the rise time of the pulse can be seen in Figure 1.

The highest curve “ABB Special Insulation” applies to motors with a special winding insulation for frequency converter supply, variant code 405.

The “ABB Standard Insulation” applies to all other motors covered by this manual.

5.2.2 Phase to ground voltages

The allowed phase to ground voltage peaks at motor terminals are:

Standard Insulation 1300 V peak

Special Insulation 1800 V peak

5.2.3 Selection of winding insulation for ACS800- and ACS550-converters

In the case of ABB ACS800-series and ACS550-series single drives with a diode supply unit (uncontrolled DC voltage), the selection of winding insulation and filters can be made according to table below:

Nominal supply voltage U_N of the converter	Winding insulation and filters required
$U_N \leq 500$ V	ABB Standard insulation
$U_N \leq 600$ V	ABB Standard insulation + dU/dt filters OR ABB Special insulation (variant code 405)
$U_N \leq 690$ V	ABB Special insulation (variant code 405) AND dU/dt-filters at converter output
$U_N \leq 690$ V AND cable length > 150 m	ABB Special insulation (variant code 405)

For more information on resistor braking and converters with controlled supply units, please contact ABB.

5.2.4 Selection of winding insulation with all other converters

The voltage stresses must be limited below accepted limits. Please contact the system supplier to ensure the safety of the application. The influence of possible filters must be taken into account while dimensioning the motor.

5.3 Thermal protection

Most of the motors covered by this manual are equipped with PTC thermistors in the stator windings. It is recommended to connect those to the frequency converter by appropriate means. See also chapter 3.8.2.

5.4 Bearing currents

Insulated bearings or bearing constructions, common mode filters and suitable cabling and grounding methods must be used according to the following instructions:

5.4.1 Elimination of bearing currents with ABB ACS800 and ACS550 converters

In the case of the ABB ACS800 and ACS550-series frequency converter with a diode supply unit, the following methods must be used to avoid harmful bearing currents in the motors:

Nominal Power (Pn) and / or Frame size (IEC)	Preventive measures
Pn < 100 kW	No actions needed
Pn ≥ 100 kW OR IEC 315 ≤ Frame size ≤ IEC 355	Insulated non-drive end bearing
Pn ≥ 350 kW OR IEC 400 ≤ Frame size ≤ IEC 450	Insulated non-drive end bearing AND Common mode filter at the converter

Insulated bearings which have aluminum oxide coated inner and/or outer bores or ceramic rolling elements, are recommended. Aluminum oxide coatings shall also be treated with a sealant to prevent dirt and humidity penetrating into the porous coating. For the exact type of bearing insulation, see the motor's rating plate. Changing the bearing type or insulation method without ABB's permission is prohibited.

5.4.2 Elimination of bearing currents with all other converters

The user is responsible for protecting the motor and driven equipment from harmful bearing currents. Instructions described in Chapter 5.4.1 can be used as guideline, but their effectiveness cannot be guaranteed in all cases.

5.5 Cabling, grounding and EMC

To provide proper grounding and to ensure compliance with any applicable EMC requirements, motors above 30 kW shall be cabled by shielded symmetrical cables and EMC glands, i.e. cable glands providing 360° bonding. Also for smaller motors symmetrical and shielded cables are highly recommended. Make the 360° grounding arrangement at all the cable entries as described in the instructions for the glands. Twist the cable shields into bundles and connect to the nearest ground terminal/bus bar inside the terminal box, converter cabinet, etc.

NOTE!
Proper cable glands providing 360° bonding must be used at all termination points, e.g. at motor, converter, possible safety switch, etc.

For motors of frame size IEC 280 and upward, additional potential equalization between the motor frame and the driven equipment is needed, unless both are mounted on a common steel base. In this case, the high frequency conductivity of the connection provided by the steel base should be checked by, for example, measuring the potential difference between the components.

More information about grounding and cabling of variable speed drives can be found in the manual "Grounding and cabling of the drive system" (Code: 3AFY 61201998).

5.6 Operating speed

For speeds higher than the nominal speed stated on the motor's rating plate or in the respective product catalogue, ensure that either the highest permissible rotational speed of the motor or the critical speed of the whole application is not exceeded.

5.7 Dimensioning the motor for variable speed application

5.7.1 General

In case of ABB's frequency converters, the motors can be dimensioned by using ABB's DriveSize dimensioning program. The tool is downloadable from the ABB website (www.abb.com/motors&generators).

For application supplied by other converters, the motors must be dimensioned manually. For more information, please contact ABB.

The loadability curves (or load capacity curves) are based on nominal supply voltage. Operation in under or over voltage conditions may influence on the performance of the application.

5.7.2 Dimensioning with ABB ACS800 converters with DTC control

The loadability curves presented in Figures 4a - 4d are valid for ABB ACS800 converters with uncontrolled DC-voltage and DTC-control. The figures show the approximate maximum continuous output torque of the motors as a function of supply frequency. The output torque is given as a percentage of the nominal torque of the motor. The values are indicative and exact values are available on request.

NOTE!
The maximum speed of the motor must not be exceeded!

5.7.3 Dimensioning with ABB ACS550 converters

The loadability curves presented in Figures 5a - 5d are valid for ABB ACS550 series converters. The figures show the approximate maximum continuous output torque of the motors as a function of supply frequency. The output torque is given as a percentage of the nominal torque of the motor. The values are indicative and exact values are available on request.

NOTE!
The maximum speed of the motor must not be exceeded!

5.7.4 Dimensioning with other voltage source PWM-type converters

For other converters, which have uncontrolled DC voltage and minimum switching frequency of 3 kHz, the dimensioning instructions of ACS550 can be used as guidelines, but it shall be noted, that the actual thermal loadability can also be lower. Please contact the manufacturer of the converter or the system supplier.

NOTE!
The actual thermal loadability of a motor may be lower than shown by guideline curves.

5.7.5 Short time overloads

ABB motors can usually be temporarily overloaded as well as used in intermittent duties. The most convenient method to dimension such applications is to use the DriveSize tool.

5.8 Rating plates

The usage of ABB's motors in variable speed applications do not usually require additional rating plates and the parameters required for commissioning the converter can be found from the main rating plate. However, in some

special applications the motors can be equipped with additional rating plates for variable speed applications and those include following information:

- speed range
- power range
- voltage and current range
- type of torque (constant or quadratic)
- converter type and required minimum switching frequency

5.9 Commissioning the variable speed application

The commissioning of the variable speed application must be done according to the instructions of the frequency converter and local laws and regulations. The requirements and limitations set by the application must also be taken into account.

All parameters needed for setting the converter must be taken from the motor rating plates. The most often needed parameters are:

- Motor nominal voltage
- Motor nominal current
- Motor nominal frequency
- Motor nominal speed
- Motor nominal power

Note: In case of missing or inaccurate information, do not operate the motor before ensuring correct settings!

ABB recommends using all the suitable protective features provided by the converter to improve the safety of the application. Converters usually provide features such as (names and availability of features depend on manufacturer and model of the converter):

- Minimum speed
- Maximum speed
- Acceleration and deceleration times
- Maximum current
- Maximum Torque
- Stall protection

6. Maintenance

WARNING

Voltage may be connected at standstill inside the terminal box for heating elements or direct winding heating.

WARNING

The capacitor in single-phase motors can retain a charge that appears across the motor terminals, even when the motor has reached standstill.

WARNING

A motor with frequency converter supply may energize even if the motor is at standstill.

6.1. General inspection

1. Inspect the motor at regular intervals, at least once a year. The frequency of checks depends on, for example, the humidity level of the ambient air and on the local weather conditions. This can initially be determined experimentally and must then be strictly adhered to.
2. Keep the motor clean and ensure free ventilation airflow. If the motor is used in a dusty environment, the ventilation system must be regularly checked and cleaned.
3. Check the condition of shaft seals (e.g. V-ring or radial seal) and replace if necessary.
4. Check the condition of connections and mounting and assembly bolts.
5. Check the bearing condition by listening for any unusual noise, vibration measurement, bearing temperature, inspection of spent grease or SPM bearing monitoring. Pay special attention to bearings when their calculated rated life time is coming to an end.

When signs of wear are noticed, dismantle the motor, check the parts and replace if necessary. When bearings are changed, replacement bearings must be of the same type as those originally fitted. The shaft seals have to be replaced with seals of the same quality and characteristics as the originals when changing bearings.

In the case of the IP 55 motor and when the motor has been delivered with a plug closed, it is advisable to periodically open the drain plugs in order to ensure that the way out for condensation is not blocked and allows condensation to escape from the motor. This operation must be done when the motor is at a standstill and has been made safe to work on.

6.2 Lubrication

WARNING

Beware of all rotating parts!

WARNING

Grease can cause skin irritation and eye inflammation. Follow all safety precautions specified by the manufacturer.

Bearing types are specified in the respective product catalogs and on the rating plate of all motors except smaller frame sizes.

Reliability is a vital issue for bearing lubrication intervals. ABB uses mainly the L_{10} -principle (i.e. that 99% of the motors are certain to make the life time) for lubrication.

6.2.1 Machines with permanently greased bearings

Bearings are usually permanently greased bearings of 1Z, 2Z, 2RS or equivalent types.

As a guide, adequate lubrication for sizes up to 250 can be achieved for the following duration, according to L_{10} .

Duty hours for permanently greased bearings at ambient temperatures of 25 and 40° C are:

Lubrication intervals according to L_{10} principle

Frame size	Poles	Duty hours	
		at 25° C	at 40° C
56-63	2-8	40 000	40 000
71	2	40 000	40 000
71	4-8	40 000	40 000
80-90	2	40 000	40 000
80-90	4-8	40 000	40 000
100-112	2	40 000	32 000
100-112	4-8	40 000	40 000
132	2	40 000	27 000
132	4-8	40 000	40 000
160	2	40 000	36 000
160	4-8	40 000	40 000
180	2	38 000	38 000
180	4-8	40 000	40 000
200	2	27 000	27 000
200	4-8	40 000	40 000
225	2	23 000	18 000
225	4-8	40 000	40 000
250	2	16 000	13 000
250	4-8	40 000	39 000

Data valid at 50 Hz, for 60 Hz reduce values for 20 %.

These values are valid for permitted load values given in the product catalog. Depending on application and load conditions, see the applicable product catalog or contact ABB.

Operation hours for vertical motors are half of the above values.

6.2.2 Motors with regreasable bearings

Lubrication information plate and general lubrication advice

If the machine is equipped with a lubrication information plate, follow the given values.

On the lubrication information plate, greasing intervals regarding mounting, ambient temperature and rotational speed are defined.

During the first start or after a bearing lubrication a temporary temperature rise may appear, approximately 10 to 20 hours.

Some motors may be equipped with a collector for old grease. Follow the special instructions given for the equipment.

A. Manual lubrication

Regreasing while the motor is running

- Remove grease outlet plug or open closing valve if fitted.
- Be sure that the lubrication channel is open
- Inject the specified amount of grease into the bearing.
- Let the motor run for 1-2 hours to ensure that all excess grease is forced out of the bearing. Close the grease outlet plug or closing valve if fitted.

Regreasing while the motor is at a standstill

If it is not possible to regrease the bearings while the motors are running, lubrication can be carried out while the machine is at a standstill.

- In this case use only half the quantity of grease and then run the motor for a few minutes at full speed.
- When the motor has stopped, apply the rest of the specified amount of grease to the bearing.
- After 1-2 running hours close the grease outlet plug or closing valve if fitted.

B. Automatic lubrication

The grease outlet plug must be removed permanently with automatic lubrication or open closing valve if fitted.

ABB recommends only the use of electromechanical systems.

The amount of grease per lubrication interval stated in the table should be multiplied by four if an automatic regreasing system is used.

When 2-pole motors are automatically regreased, the note concerning lubricant recommendations for 2-pole motors in the Lubricants chapter should be followed.

6.2.3 Lubrication intervals and amounts

As a guide, adequate lubrication for motors with regreasable bearings can be achieved for the following duration, according to L_1 . For duties with higher ambient temperatures please contact ABB. The formula to change the L_1 values roughly to L_{10} values: $L_{10} = 2.7 \times L_1$.

Lubrication intervals for vertical machines are half of the values shown in the table below.

The lubrication intervals are based on an ambient temperature +25°C. An increase in the ambient temperature raises the temperature of the bearings correspondingly. The values should be halved for a 15°C increase and may be doubled for a 15°C decrease.

In variable speed operation (i.e. frequency converter supply) it is necessary to measure the bearing temperature for the whole duty range and if exceeds 80°C, the lubrication intervals should be halved for a 15°C increase in bearing temperature. If the motor is operated at high speeds, it is also possible to utilize so called high speed greases, see chapter 6.2.4.

WARNING

The maximum operating temperature of the grease and bearings, +110°C, must not be exceeded.
The designed maximum speed of the motor must not be exceeded.

Lubrication intervals according to L₁ principle

Frame size	Amount of grease g/bearing	kW	3600 r/min	3000 r/min	kW	1800 r/min	1500 r/min	kW	1000 r/min	kW	500-900 r/min
Ball bearings											
Lubrication intervals in duty hours											
112	10	all	10000	13000	all	18000	21000	all	25000	all	28000
132	15	all	9000	11000	all	17000	19000	all	23000	all	26500
160	25	≤ 18,5	9000	12000	≤ 15	18000	21500	≤ 11	24000	all	24000
160	25	> 18,5	7500	10000	> 15	15000	18000	> 11	22500	all	24000
180	30	≤ 22	7000	9000	≤ 22	15500	18500	≤ 15	24000	all	24000
180	30	> 22	6000	8500	> 22	14000	17000	> 15	21000	all	24000
200	40	≤ 37	5500	8000	≤ 30	14500	17500	≤ 22	23000	all	24000
200	40	> 37	3000	5500	> 30	10000	12000	> 22	16000	all	20000
225	50	≤ 45	4000	6500	≤ 45	13000	16500	≤ 30	22000	all	24000
225	50	> 45	1500	2500	> 45	5000	6000	> 30	8000	all	10000
250	60	≤ 55	2500	4000	≤ 55	9000	11500	≤ 37	15000	all	18000
250	60	> 55	1000	1500	> 55	3500	4500	> 37	6000	all	7000
280 ¹⁾	60	all	2000	3500	-	-	-	-	-	-	-
280 ¹⁾	60	-	-	-	all	8000	10500	all	14000	all	17000
280	35	all	1900	3200	-	-	-	-	-	-	-
280	40	-	-	-	all	7800	9600	all	13900	all	15000
315	35	all	1900	3200	-	-	-	-	-	-	-
315	55	-	-	-	all	5900	7600	all	11800	all	12900
355	35	all	1900	3200	-	-	-	-	-	-	-
355	70	-	-	-	all	4000	5600	all	9600	all	10700
400	40	all	1500	2700	-	-	-	-	-	-	-
400	85	-	-	-	all	3200	4700	all	8600	all	9700
450	40	all	1500	2700	-	-	-	-	-	-	-
450	95	-	-	-	all	2500	3900	all	7700	all	8700

Roller bearings											
Lubrication intervals in duty hours											
160	25	≤ 18,5	4500	6000	≤ 15	9000	10500	≤ 11	12000	all	12000
160	25	> 18,5	3500	5000	> 15	7500	9000	> 11	11000	all	12000
180	30	≤ 22	3500	4500	≤ 22	7500	9000	≤ 15	12000	all	12000
180	30	> 22	3000	4000	> 22	7000	8500	> 15	10500	all	12000
200	40	≤ 37	2750	4000	≤ 30	7000	8500	≤ 22	11500	all	12000
200	40	> 37	1500	2500	> 30	5000	6000	> 22	8000	all	10000
225	50	≤ 45	2000	3000	≤ 45	6500	8000	≤ 30	11000	all	12000
225	50	> 45	750	1250	> 45	2500	3000	> 30	4000	all	5000
250	60	≤ 55	1000	2000	≤ 55	4500	5500	≤ 37	7500	all	9000
250	60	> 55	500	750	> 55	1500	2000	> 37	3000	all	3500
280 ¹⁾	60	all	1000	1750	-	-	-	-	-	-	-
280 ¹⁾	70	-	-	-	all	4000	5250	all	7000	all	8500
280	35	all	900	1600	-	-	-	-	-	-	-
280	40	-	-	-	all	4000	5300	all	7000	all	8500
315	35	all	900	1600	-	-	-	-	-	-	-
315	55	-	-	-	all	2900	3800	all	5900	all	6500
355	35	all	900	1600	-	-	-	-	-	-	-
355	70	-	-	-	all	2000	2800	all	4800	all	5400
400	40	all	-	1300	-	-	-	-	-	-	-
400	85	-	-	-	all	1600	2400	all	4300	all	4800
450	40	all	-	1300	-	-	-	-	-	-	-
450	95	-	-	-	all	1300	2000	all	3800	all	4400

1) M3AA

For motors M4BP 160 to 250 the interval may be increased by 30 %, up to a maximum of three calendar years. The values in table above are valid also for sizes M4BP 280 to 355.

6.2.4 Lubricants

WARNING

Do not mix different types of grease.

Incompatible lubricants may cause bearing damage.

When regreasing, use only special ball bearing grease with the following properties:

- good quality grease with lithium complex soap and with mineral- or PAO-oil
- base oil viscosity 100-160 cST at 40°C
- consistency NLGI grade 1.5 - 3 *)
- temperature range -30°C - +120°C, continuously.

*) For vertical mounted motors or in hot conditions a stiffer end of scale is recommended.

The above mentioned grease specification is valid if the ambient temperature is above -30°C or below +55°C, and the bearing temperature is below 110°C; otherwise consult ABB regarding suitable grease.

Grease with the correct properties is available from all the major lubricant manufacturers.

Admixtures are recommended, but a written guarantee must be obtained from the lubricant manufacturer, especially concerning EP admixtures, that admixtures do not damage bearings or the properties of lubricants at the operating temperature range.

WARNING

Lubricants containing EP admixtures are not recommended in high bearing temperatures in frame sizes 280 to 450.

The following high performance greases can be used:

- Esso Unirex N2 or N3 (lithium complex base)
- Mobil Mobilith SHC 100 (lithium complex base)
- Shell Albida EMS 2 (lithium complex base)
- Klüber Klüberplex BEM 41-132 (special lithium base)
- FAG Arcanol TEMP110 (lithium complex base)
- Lubcon Turmogrease L 802 EP PLUS (special lithium base)
- Total Multiplex S 2 A (lithium complex base)

NOTE!

Always use high speed grease for high speed 2-pole machines where the speed factor is higher than 480,000 (calculated as $D_m \times n$ where D_m = average bearing diameter, mm; n = rotational speed, r/min). The high speed grease is also used in motor types M2CA, M2FA, M2CG and M2FG, frame sizes 355 to 400 2-pole machines.

The following greases can be used for high speed cast iron motors but not mixed with lithium complex greases:

- Klüber Klüber Quiet BQH 72-102 (polyurea base)
- Lubcon Turmogrease PU703 (polyurea base)

If other lubricants are used;

Check with the manufacturer that the qualities correspond to those of the above mentioned lubricants. The lubrication interval are based on the listed high performance greases above. Using other greases can reduce the interval.

If the compatibility of the lubricant is uncertain, contact ABB.

7. After Sales Support



7.1. Spare parts

When ordering spare parts, the motor serial number, full type designation and product code, as stated on the rating plate, must be specified.

For more information, please visit our web site www.abb.com/partsonline.

7.2 Rewinding

Rewinding should always be carried out by qualified repair shops.

Smoke venting and other special motors should not be rewound without first contacting ABB.

7.3 Bearings

Special care should be taken with the bearings. These must be removed using pullers and fitted by heating or using special tools for the purpose.

Bearing replacement is described in detail in a separate instruction leaflet available from the ABB Sales Office.

8. Environmental requirements

8.1 Noise levels

Most of ABB's motors have a sound pressure level not exceeding 82 dB(A) at 50 Hz .

Values for specific machines can be found in the relevant product catalogues. At 60 Hz sinusoidal supply the values are approximately 4 dB(A) higher compared to 50 Hz values in product catalogues.

For sound pressure levels at frequency converter supply, please contact ABB.

Sound pressure levels for all machines having separate cooling systems and for series M2F*/M3F*, M2L*/M3L*, M2R*/M3R*, M2BJ/M3BJ and M2LJ/M3LJ are indicated in separate additional manuals.

9. Troubleshooting

These instructions do not cover all details or variations in equipment nor provide for every possible condition to be met in connection with installation, operation or maintenance. Should additional information required, please contact the nearest ABB Sales Office.

Motor troubleshooting chart

Your motor service and any troubleshooting must be handled by qualified persons who have proper tools and equipment.

TROUBLE	CAUSE	WHAT TO DO
Motor fails to start	Blown fuses	Replace fuses with proper type and rating.
	Overload trips	Check and reset overload in starter.
	Improper power supply	Check to see that power supplied agrees with motor rating plate and load factor.
	Improper line connections	Check connections against diagram supplied with motor.
	Open circuit in winding or control switch	Indicated by humming sound when switch is closed. Check for loose wiring connections. Also ensure that all control contacts are closing.
	Mechanical failure	Check to see if motor and drive turn freely. Check bearings and lubrication.
	Short circuited stator Poor stator coil connection	Indicated by blown fuses. Motor must be rewound. Remove end shields, locate fault.
	Rotor defective	Look for broken bars or end rings.
	Motor may be overloaded	Reduce load.
Motor stalls	One phase may be open	Check lines for open phase.
	Wrong application	Change type or size. Consult equipment supplier.
	Overload	Reduce load.
	Low voltage	Ensure the rating plate voltage is maintained. Check connection.
	Open circuit	Fuses blown, check overload relay, stator and push buttons.
Motor runs and then dies down	Power failure	Check for loose connections to line, to fuses and to control.
Motor does not come up to nominal speed	Not applied properly	Consult equipment supplier for proper type.
	Voltage too low at motor terminals because of line drop	Use higher voltage or transformer terminals or reduce load. Check connections. Check conductors for proper size.
	Starting load too high	Check the start load of the motor.
	Broken rotor bars or loose rotor	Look for cracks near the rings. A new rotor may be required, as repairs are usually temporary.
	Open primary circuit	Locate fault with testing device and repair.

TROUBLE	CAUSE	WHAT TO DO
Motor takes too long to accelerate and/or draws high current	Excessive load	Reduce load.
	Low voltage during start	Check for high resistance. Make sure that adequate cable size is used.
	Defective squirrel cage rotor	Replace with new rotor.
	Applied voltage too low	Correct power supply.
Wrong rotation direction	Wrong sequence of phases	Reverse connections at motor or at switchboard.
Motor overheats while running	Overload	Reduce load.
	Frame or ventilation openings may be full of dirt and prevent proper ventilation of motor	Open vent holes and check for a continuous stream of air from the motor.
	Motor may have one phase open	Check to make sure that all leads are well connected.
	Grounded coil	Motor must be rewound
	Unbalanced terminal voltage	Check for faulty leads, connections and transformers.
Motor vibrates	Motor misaligned	Realign.
	Weak support	Strengthen base.
	Coupling out of balance	Balance coupling.
	Driven equipment unbalanced	Rebalance driven equipment.
	Defective bearings	Replace bearings.
	Bearings not in line	Repair motor.
	Balancing weights shifted	Rebalance motor.
	Contradiction between balancing of rotor and coupling (half key - full key)	Rebalance coupling or motor.
	Polyphase motor running single phase	Check for open circuit.
	Excessive end play	Adjust bearing or add shim.
Scraping noise	Fan rubbing end shield or fan cover	Correct fan mounting.
	Loose on bedplate	Tighten holding bolts.
Noisy operation	Air gap not uniform	Check and correct end shield fits or bearing fits.
	Rotor unbalance	Rebalance rotor.
Hot bearings	Bent or sprung shaft	Straighten or replace shaft.
	Excessive belt pull	Decrease belt tension.
	Pulleys too far away from shaft shoulder	Move pulley closer to motor bearing.
	Pulley diameter too small	Use larger pulleys.
	Misalignment	Correct by realignment of the drive.
	Insufficient grease	Maintain proper quality and amount of grease in bearing.
	Deterioration of grease or lubricant contaminated	Remove old grease, wash bearings thoroughly in kerosene and replace with new grease.
	Excess lubricant	Reduce quantity of grease, bearing should not be more than half full.
	Overloaded bearing	Check alignment, side and end thrust.
	Broken ball or rough races	Replace bearing, clean housing thoroughly first.

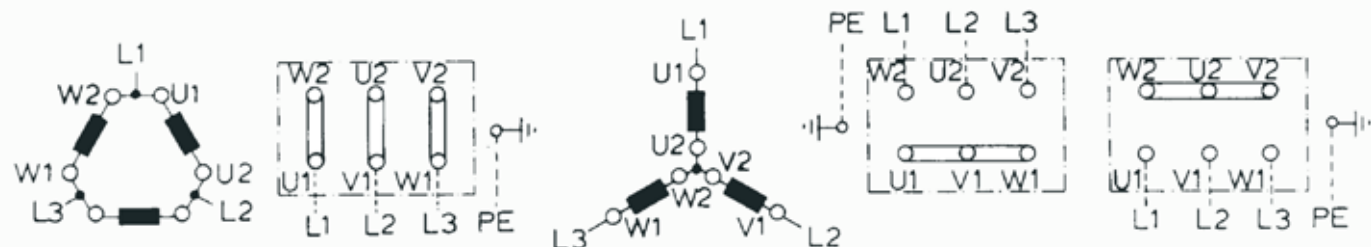

Figure 1. Connection diagram

Bild 1. Anschlußdiagramm

Figure 1. Connection

Figura 1. Conexión

Figura 1. Collegamento

Figur 1. Anslutningdiagramm

Kuva 1. Kytentäkaavio

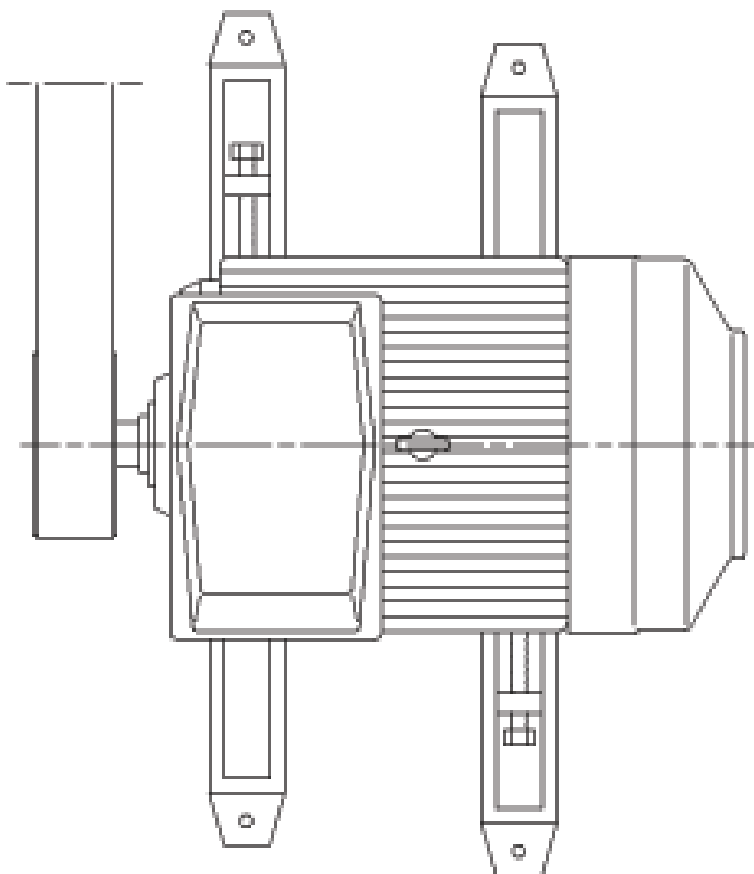

Figure 2. Belt drive

Bild 2. Riementrieb

Figure 2. Glissières et entraînements à courroie

Figure 2. Carriles tensores y correas

Figura 2. Slitte tendicinghia e pulegge

Figur 2. Remdrift

Kuva 2. Hihnäkäyttö

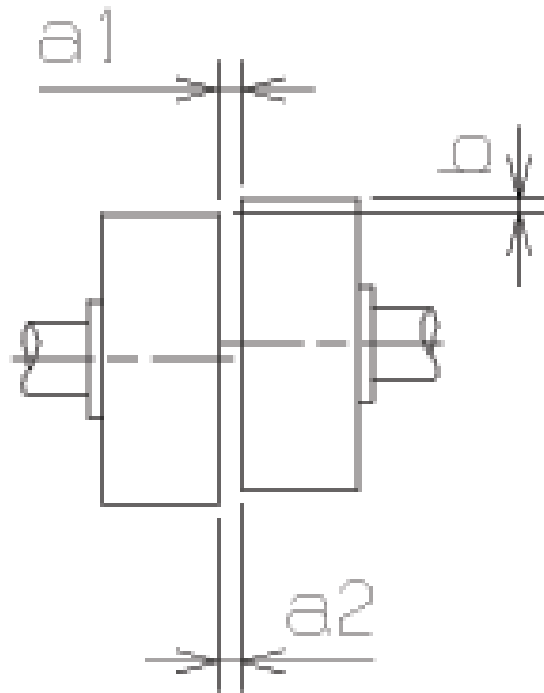

Figure 3. Mounting of half-coupling or pulley

Bild 3. Anbau von Kupplungshälften und Riemenscheiben

Figure 3. Montage des demi-accouplements et des poulies

Figura 3. Montaje de mitades de acoplamiento y poleas

Figura 3. Montaggio di semigiunti e pulegge

Figur 3. Montering av kopplinshalvor och drivskivor

Kuva 3. Kytkinpuolikkaan ja hihnapyörän asennus

Loadability curves with ACS800 converters with DTC control
Belastbarkeitskurven für ACS800-Frequenzumrichter mit DTC-Steuerung
Courbes de capacité de charge avec convertisseurs ACS800 et commande DTC
Curvas de capacidad de carga con convertidores ACS800 dotados de control DTC
Curve di caricabilità con convertitori ACS800 e controllo DTC
Lastbarhetskurvor för ACS800-omriktare med DTC-styrning
Kuormitettavuuskäyrät DTC-säädöllä varustetuille ACS800-taajuusmuuttajille

Figures/Abbildungen/Figures/Figure/Figure/Figur/Kuvat 4a, 4b, 4c, 4d

Low voltage motors, nominal frequency of the motors 50/60 Hz, temperature rise B/F
 Niederspannungsmotoren, Nennfrequenz der Motoren 50/60 Hz, Temperaturanstieg B/F
 Moteurs à basse tension, fréquence nominale des moteurs de 50/60 Hz, augmentation de température B/F
 Motores de baja tensión, frecuencia nominal de los motores 50/60 Hz, aumento de temperatura B/F
 Motori a bassa tensione, frequenza nominale dei motori 50/60 Hz, incremento di temperatura B/F
 Lågspänningsmotorer, märkfrekvens för motorerna 50/60 Hz, temperaturstegring B/F
 Pienjännitemoottorit, moottorin nimellistaajuus 50/60 Hz, lämpötilan nousu B/F

4a ACS800/50 Hz, Temperature rise B

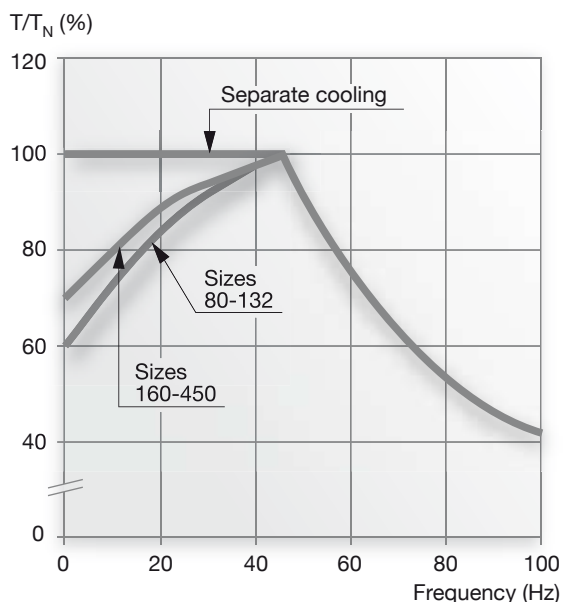

4b ACS800/60 Hz, Temperature rise B

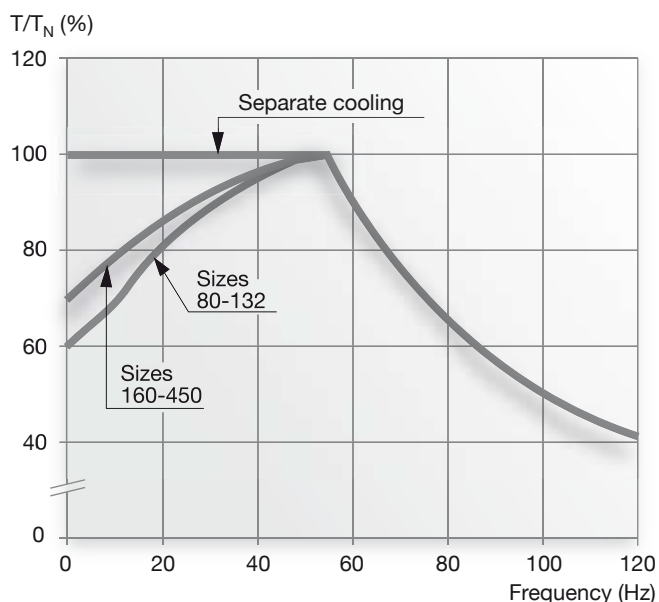

4c ACS800/50 Hz, Temperature rise F

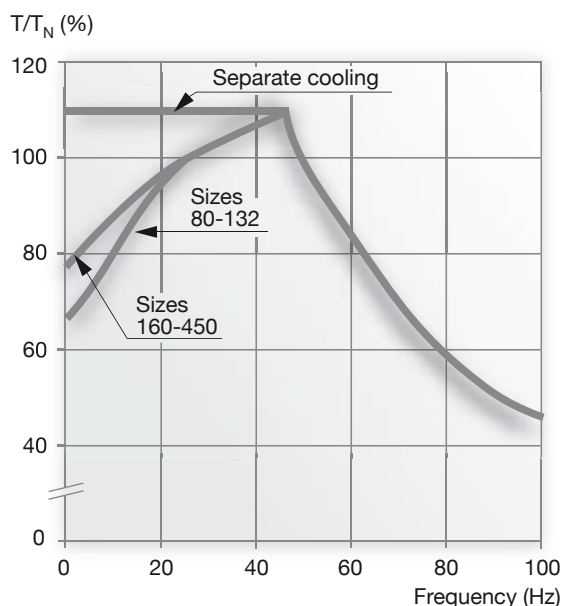

4d ACS800/60 Hz, Temperature rise F

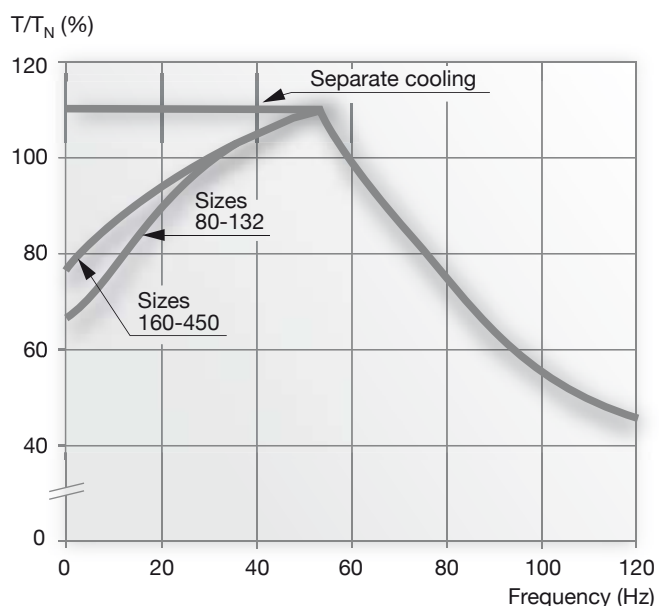

Loadability curves with ACS550 converters
Belastbarkeitskurven für ACS550-Frequenzumrichter
Courbes de capacité de charge avec convertisseurs ACS550
Curvas de capacidad de carga con convertidores ACS550
Curve di caricabilità con convertitori ACS550
Lastbarhetskurvor för ACS550-omriktare
Kuormitettavuuskäyrät ACS550-taajuusmuuttajille

Figures/Abbildungen/Figures/Figure/Figure/Figur/Kuvat 5a, 5b, 5c, 5d

Low voltage motors, nominal frequency of the motors 50/60 Hz, temperature rise B/F
 Niederspannungsmotoren, Nennfrequenz der Motoren 50/60 Hz, Temperaturanstieg B/F
 Moteurs à basse tension, fréquence nominale des moteurs de 50/60 Hz, augmentation de température B/F
 Motores de baja tensión, frecuencia nominal de los motores 50/60 Hz, aumento de temperatura B/F
 Motori a bassa tensione, frequenza nominale dei motori 50/60 Hz, incremento di temperatura B/F
 Lågspänningsmotorer, märkfrekvens för motorerna 50/60 Hz, temperaturstegring B/F
 Pienjännitemoottorit, moottorin nimellistaajuus 50/60 Hz, lämpötilan nousu B/F

5a ACS550/50 Hz, Temperature rise B

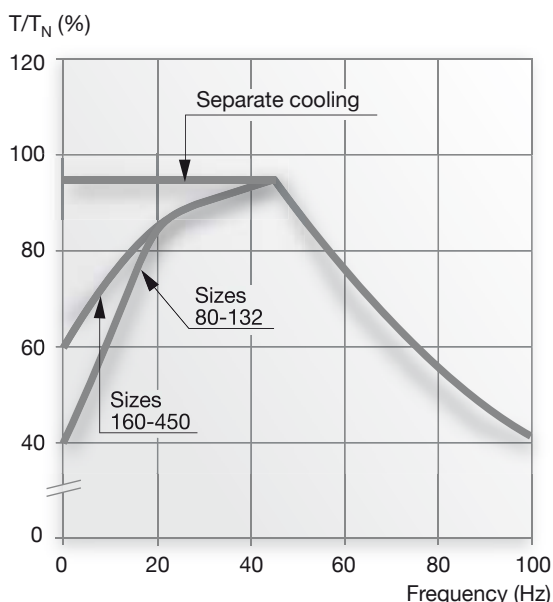

5b ACS550/60 Hz, Temperature rise B

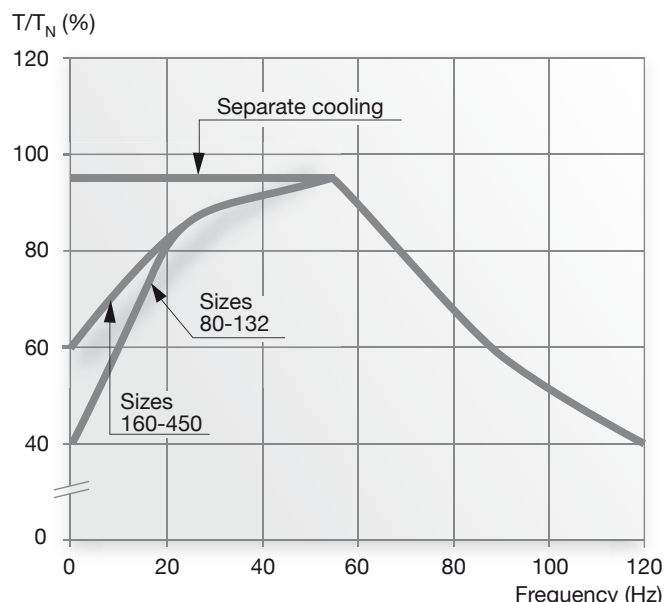

5c ACS550/50 Hz, Temperature rise F

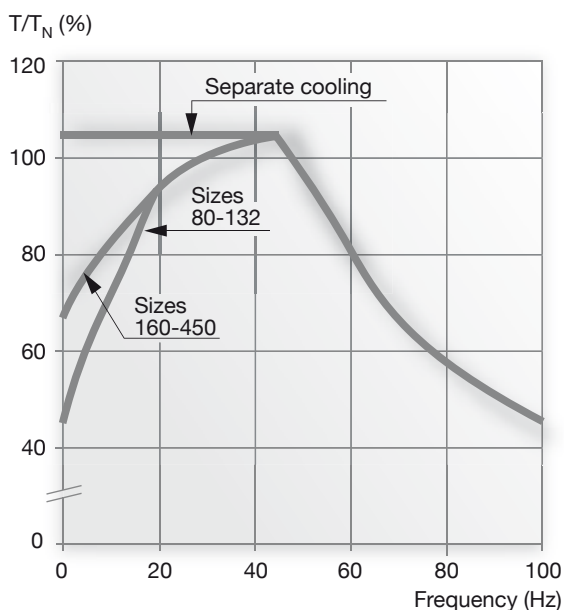

5d ACS550/60 Hz, Temperature rise F

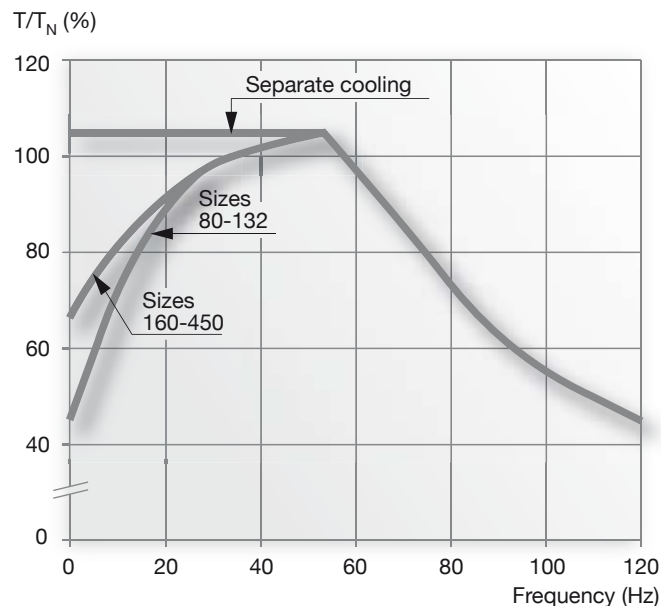

Low Voltage Motors

Manufacturing sites (*) and some of the larger sales companies.

Australia

ABB Australia Pty Ltd
601 Blackburn Road
Notting Hill VIC 3168
Tel: +61 (0) 8544 0000
Fax: +61 (0) 8544 0001

Austria

ABB AG
Clemens Holzmeisterstrasse 4
A-1109 Wien
Tel: +43 (0) 1 601 090
Fax: +43 (0) 1 601 09 8305

Belgium

Asea Brown Boveri S.A.-N.V.
Hoge Wei 27
BE-1930 Zaventem
Tel: +32 (0) 2 718 6311
Fax: +32 (0) 2 718 6657

Canada

ABB Inc., BA Electrical Machines
10300 Henri-Bourassa Blvd, West,
Saint-Laurent, Quebec
Canada H4S 1N6
Tel: +1 514 832-6583
Fax: +1 514 332-0609

China*

ABB Shanghai Motors Co., Ltd.
88 Tianning Road
Minhang(Economical and Techno-
logical Development Zone)
200245 Shanghai
Tel: +86 21 5472 3133
Fax: +86 21 5472 5025

Chile

ABB S.A.
Vicuña Mackenna 1602, Nuñoa
Santiago
Tel: +56 (0) 2 471 4000
Fax: +56 (0) 2 471 4503

Denmark

ABB A/S
Automation Products
Emil Neckelmanns Vej 14
DK-5220 Odense SØ
Tel: +45 65 47 70 70
Fax: +45 65 47 77 13

Finland*

ABB Oy
Motors
P.O.Box 633
FI-65101 Vaasa
Tel: +358 (0) 10 22 11
Fax: +358 (0) 10 22 47372

France

ABB Entelec
ZA La Boisse BP 90145
300 Rue des Prés-Seigneurs
FR-01124 Montluel Cedex
Tel: +33 4 37 40 40 00
Fax: +33 4 37 40 40 72

Germany

ABB Automation Products GmbH
Motors & Drives
Wallstaedter Strasse 59
DE-68526 Ladenburg
Tel: +49 (0) 6203 717 717
Fax: +49 (0) 6203 717 600

Hong Kong

ABB (Hong Kong) Ltd.
Tai Po Industrial Estate,
3 Dai Hei Street,
Tai Po, New Territories,
Hong Kong
Tel: +852 2929 3838
Fax: +852 2929 3505

India*

ABB Ltd.
32, Industrial Area, N.I.T
Faridabad 121 001
Tel: +91 (0) 129 502 3001
Fax: +91 (0) 129 502 3006

Indonesia

PT. ABB Sakti Industri
JL. Gajah Tunggal Km.1
Jatiuwung, Tangerang 15136
Banten, Indonesia
Tel: +62 21 590 9955
Fax: +62 21 590 0115 - 6

Ireland

Asea Brown Boveri Ltd
Components Division
Belgard Road
Tallaght, Dublin 24
Tel: +353 (0) 1 405 7300
Fax: +353 (0) 1 405 7327

Italy*

ABB SACE SpA
LV Motors
Via dell' Industria 18
IT-20010 Vittuone, Milano
Tel: +39 02 90341
Fax: +39 02 9034 7289

Japan

ABB K.K.
26-1 Cerulean Tower
Sakuragaoka-cho, Shibuya-ku
Tokyo 150-8512
Tel: +81 (0) 3 578 46251
Fax: +81 (0) 3 578 46260

Korea

ABB Korea Ltd.
7-9fl, Oksan Bldg., 157-33
Sungshung-dong, Kangnam-ku
Seoul
Tel: +82 2 528 2329
Fax: +82 2 528 2338

Malaysia

ABB Malaysia Sdn. Bhd.
Lot 608, Jalan SS 13/1K
47500 Subang Jaya, Selangor
Tel: +60 3 5628 4888
Fax: +60 3 5631 2926

Mexico

ABB México, S.A. de C.V.
Apartado Postal 111
CP 54000 Tlalnepantla
Edo. de México, México
Tel: +52 5 328 1400
Fax: +52 5 390 3720

The Netherlands

ABB B.V.
Dept. LV motors (APP2R)
P.O.Box 301
NL-3000 AH Rotterdam
Tel: +31 (0) 10 4078 879
Fax: +31 (0) 10 4078 345

Norway

ABB AS
P.O.Box 154 Vollebakk
NO-0520 Oslo
Tel: +47 22 872 000
Fax: +47 22 872 541

Russia

ABB Industrial & Building Systems
Ltd.
Business Centre "Krugozor"
Obrucheva 30/1, Building 2
Moscow 117861
Tel: +7 495 960 2200, 956 93 93
Fax: +7 495 960 2209, 230 63 46

Singapore

ABB Industry Pte Ltd
2 Ayer Rajah Crescent
Singapore 139935
Tel: +65 6776 5711
Fax: +65 6778 0222

Spain*

Asea Brown Boveri S.A.
Automation Products - Fábrica
Motores
P.O.Box 81
ES-08200 Sabadell
Tel: +34 93 728 8500
Fax: +34 93 728 8741

Sweden*

ABB AB
LV Motors
SE-721 70 Västerås
Tel: +46 (0) 21 329 000
Fax: +46 (0) 21 329 140

Switzerland

ABB Schweiz AG
Normelec/CMC Components
Motors&Drives
Badenerstrasse 790
Postfach
CH-8048 Zürich
Tel: +41 (0) 58 586 0000
Fax: +41 (0) 58 586 0603

Taiwan

ABB Ltd.
6F, No. 126, Nanking East Road,
Section 4i
Taipei, 105 Taiwan, R.O.C.
Tel: +886 (0) 2 2577 6090
Fax: +886 (0) 2 2577 9467

Thailand

ABB Limited (Thailand)
161/1 SG Tower,
Soi Mahadlekluang 3,
Rajdamri, Bangkok 10330
Tel: +66 2 665 1000
Fax: +66 2 665 1042

The United Kingdom

ABB Ltd
Drives, Motors and Machines
Daresbury Park
Daresbury, Warrington
Cheshire, WA4 4BT
Tel: +44 (0) 1925 741 111
Fax: +44 (0) 1925 741 212

USA

ABB Inc.
Low Voltage Motors
16250 W. Glendale Drive
New Berlin, WI 53151
Tel: +1 262 785 3200
Fax: +1 262 780 8888

Venezuela

Asea Brown Boveri S.A.
P.O.Box 6649
Carmelitas,
Caracas 1010A
Tel: +58 (0) 2 238 2422
Fax: +58 (0) 2 239 6383

www.abb.com/motors&generators
<http://online.abb.com/bol>